



Enriching Lives

HORIZONTAL AXIALLY SPLIT CASING PUMPS

TYPE - UP/UPL/UPH



CE

KIRLOSKAR BROTHERS LIMITED

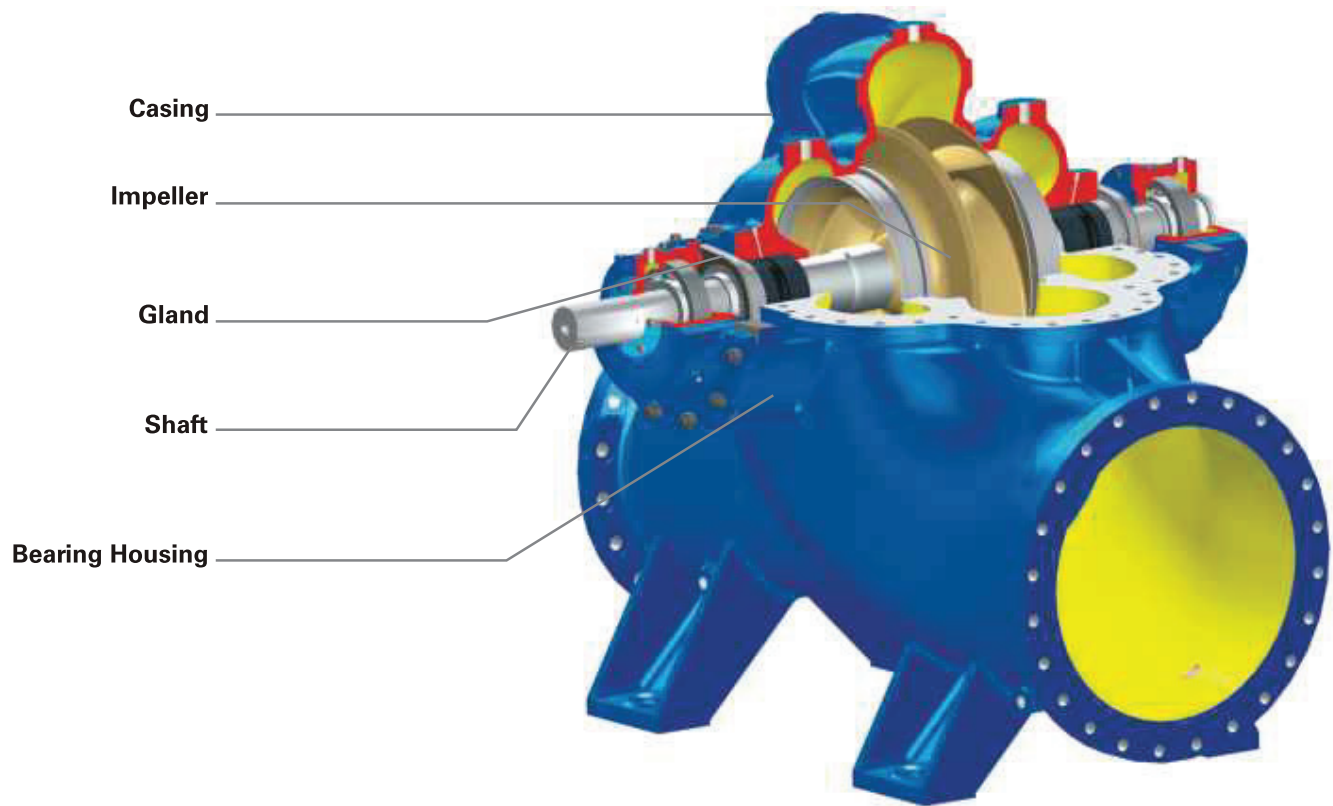

RANGE

Delivery size : up to 1220 mm
 Capacity : up to 24,000 m³/hr
 Head : up to 180 meters

APPLICATIONS

Suitable for handling water with slight impurities in Industries, Water Works, Storm Water, Irrigation, Sprinkler Irrigation Fire-fighting, Air Conditioning, Water Circulation, Waste Water Treatment, Processing, Power, Fertilizer, Refinery, Paper, Sugar and Textile Mills, etc.

CONSTRUCTIONAL FEATURES

These are horizontal axially split casing, single stage, double suction or single suction, single volute or double volute type pumps with horizontal shaft.

Special Features

Rotating assembly accessible for inspection or maintenance by removing upper half casing without disturbing suction and delivery piping and motor.

Horizontal execution (standard) or vertical execution (optional).

Vertical pump, direct drive or with universal shaft arrangement.

High hydraulic and overall efficiency due to superior design and manufacturing techniques.

Good suction performance and low NPSH.

Stable characteristics, minimum maintenance required, vibration free performance.

High reliability.

Pump Casing :

Horizontal axially split volute type, suction and discharge nozzles and supporting feet are cast integral with lower half casing.

Impeller :

Double or single suction type accurately balanced. In case of double suction impellers, the hydraulic thrust is balanced automatically because of pressure equalization on both sides of the impeller.

Shafts :

The high tensile steel shaft accurately machined and ground is supported by antifriction bearings. The shaft is protected by shaft sleeves from wear in stuffing box area.

Stuffing Box :

Can be sealed by gland packing or by mechanical seal and is suitable for liquids having temperature up to 90°C.

Bearings :

Grease Lubricated deep groove ball / roller bearings are provided. Large pumps can be provided with Oil Lubricated / Oil ring bearings.

Direction Of Rotation :

Standard : Anticlockwise (ACW) when viewed from driving end.

Optional : Clockwise (CW) when viewed from driving end.

Drive :

Suitable for coupling with electric motors, engines or steam turbines either directly or through belt drives, gear boxes etc.

Flanges :

Standard :Drilled to BS : 10Table D/E/F or BS-4504,Table PN16 plain face depending upon model.

Optional :DIN /ASA with suitable pressure rating depending upon model.

GENERAL DIMENSIONS / MOUNTING DETAILS

UP Metric (Thrubore) Pumps

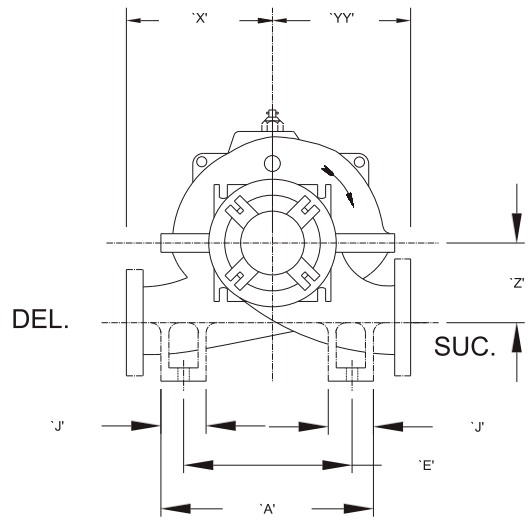
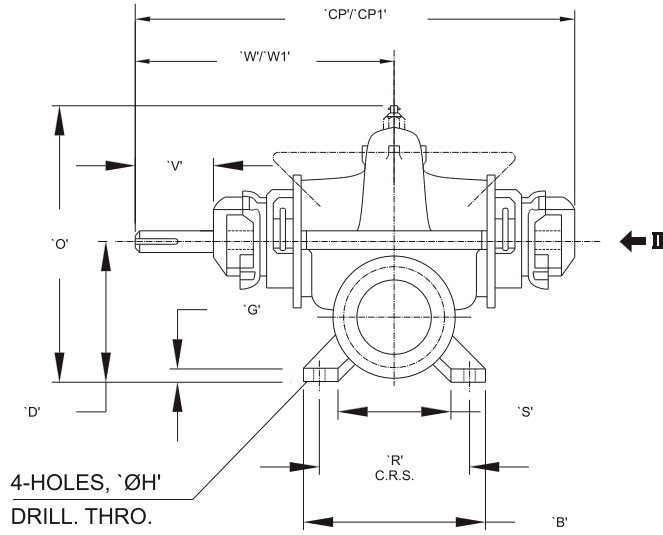

DIRECTION OF ROTATION : COUNTER CLOCKWISE FROM DRIVING END.

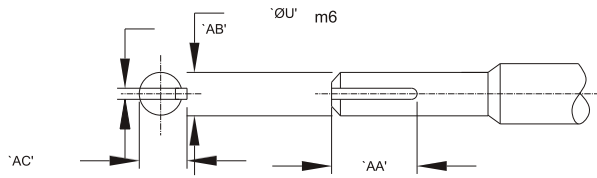

Unit No.	'U'm6	'AA'	'AB'	'AC'
0	24	44	8	27
I	25	50	8	28
IE	32	60	10	35
II	42	87	12	45
III	55	85	16	59

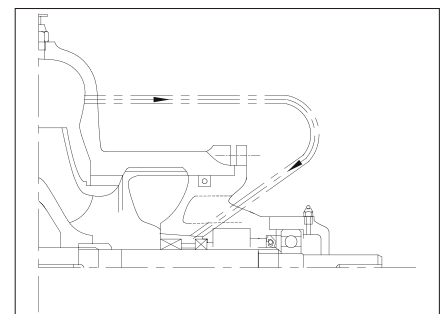
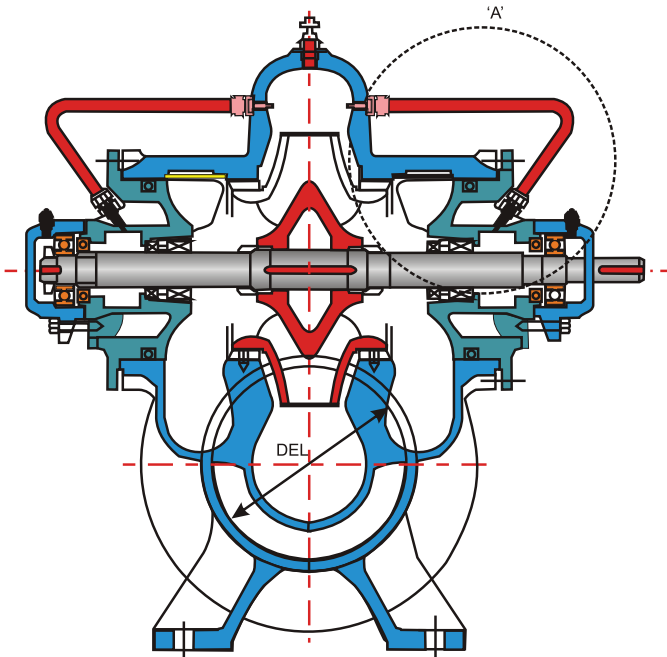

DETAILS AT - A

DIMENSIONS

PUMP TYPE	MODULE NO.	SUC	DEL	For Soft Packed																	'Wt' Kg.	For Mechanical Seal			
				'A'	'B'	'D'	'E'	'G'	'H'	'J'	'O'	'R'	'S'	'V'	'W'	'X'	'Z'	'CP'	'YY'	'L'		'W1'	'CP1'	'L1'	'Wt' Kg.
UP 50/30A	0	65	50	300	210	240	230	15	14	70	442	170	90	48	304	225	140	548	275	219	80	276	506	191	72
UP 50/30B		65	50	300	210	240	230	15	14	70	442	170	90	48	304	225	140	548	275	219	80	276	506	191	72
UP 65/24		80	65	300	210	240	230	18	14	70	440	170	90	50	306.5	210	130	565	280	221.5	84	306.5	565	221.5	84
UP 80/24		100	80	300	210	250	230	18	14	70	450	170	90	50	306.5	230	130	565	270	221.5	95	306.5	565	221.5	95
UP 65/38	I	80	65	400	240	300	300	25	23	100	575	190	100	55	375	275	175	696	325	280	164	292	530	197	150
UP 65/38M		80	65	400	240	300	300	25	23	100	565	190	100	55	375	275	175	696	325	280	164	292	530	197	150
UP 80/30		125	80	330	280	310	230	25	23	100	550	220	130	56	375	240	170	696	320	265	130	292	530	182	120
UP 80/38		100	80	440	280	310	340	25	23	100	585	220	130	56	375	285	175	696	340	265	158	292	530	182	146
UP 100/24		150	100	260	280	330	160	20	23	100	553	220	130	56	375	210	170	696	310	265	158	292	530	182	146
UP 100/29		150	100	300	280	310	200	25	23	100	540	220	130	56	375	230	160	696	310	265	137	292	530	182	124
UP 125/24		150	125	310	330	330	210	25	23	100	560	270	180	56	394	235	180	734	350	259	180	316	578	181	170
UP 125/30A		150	125	370	330	330	270	25	23	100	580	270	180	56	394	245	175	734	335	259	182	316	578	181	172
UP 125/30B		150	125	370	330	330	270	25	23	100	580	270	180	56	394	245	175	734	335	259	182	316	578	181	172
UP 100-35	IE	150	100	400	300	360	300	20	23	100	630	240	140	75	413	260	205	753	340	293	177	413	753	293	177
UP 100/38	II	150	100	440	330	360	340	25	23	100	660	270	180	90	480	300	210	872	400	345	240	378	668	243	218
UP 150/26N		200	150	500	370	385	400	25	23	100	635	300	220	90	480	355	195	897	380	330	262	480	897	330	262
UP 150/30		200	150	370	370	415	270	25	23	100	695	310	220	90	480	270	235	872	365	325	253	378	668	223	236
UP 150/30AN		200	150	500	370	385	400	25	23	100	655	300	220	90	480	355	195	897	380	330	270	480	897	330	270
UP 150/38A		200	150	450	370	390	350	25	23	100	680	310	220	90	480	310	210	872	410	325	286	378	668	223	271
UP 150/38B		200	150	450	370	390	350	25	23	100	680	310	220	90	480	310	210	872	410	325	286	378	668	223	271
UP 150/38BC		200	150	450	370	390	350	25	23	100	680	310	220	90	480	310	210	897	410	325	286	378	693	223	271
UP 150/45		200	150	450	370	450	350	25	23	100	780	310	220	90	480	355	269	872	430	325	308	378	693	223	291
UP 200/30		250	200	420	470	495	320	25	23	100	810	410	320	90	512	300	285	936	450	307	372	410	732	205	356
UP 200/38		200	200	520	470	400	420	25	23	100	720	410	320	90	512	350	225	936	480	307	350	410	732	205	331
UP 250/30		250	250	520	470	460	420	25	23	100	775	410	320	90	512	360	250	936	430	307	348	410	732	205	332
UP 250/38		250	250	570	490	475	470	25	23	100	850	410	320	90	512	420	265	936	540	307	420	410	732	205	404
UP 150/53	III	200	150	750	400	500	600	25	27	150	890	320	200	110	592	450	320	1077	500	432	588	592	1077	432	588
UP 200/42		250	200	680	400	500	530	28	27	150	840	320	200	110	592	450	270	1077	550	432	560	592	1077	432	560
UP 200/56		250	200	710	500	600	560	30	27	150	1070	400	200	110	592	450	372	1077	550	392	740	592	1077	392	740

NOTES :

- 1) All dimensions are in mm.
- 2) Flanges Drilled to BS 4504 PN 16 (FF)
- 3) For mechanical seal version other dimensions remain the same.
- 4) Standard direction of rotation anti-clockwise viewed from driving end.

GENERAL DIMENSIONS / MOUNTING DETAILS

UP/ UPH/ UPL Pump

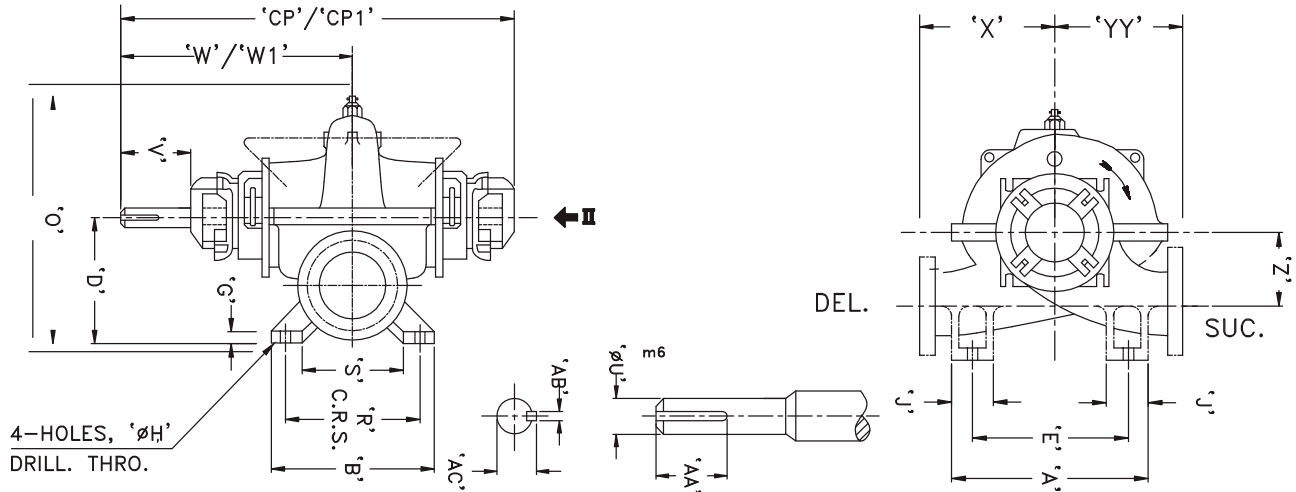

DIMENSIONS

Pump Model	SUC. DEL.		PUMP MOUNTING DIMENSIONS															SHAFT END					WT	
	ø	ø	a	a1	f	f1	f2	h1	h2	n	m1	m2	n1	n2	n3	sø	o	p	dø	l	t	u	w	kg
14UPH4/4M1	400	350	850	650	1010	875	730	900	640	240	660	560	980	370	370	33	330	330	95	160	102	25	128	2800

UP(Metric) Pump

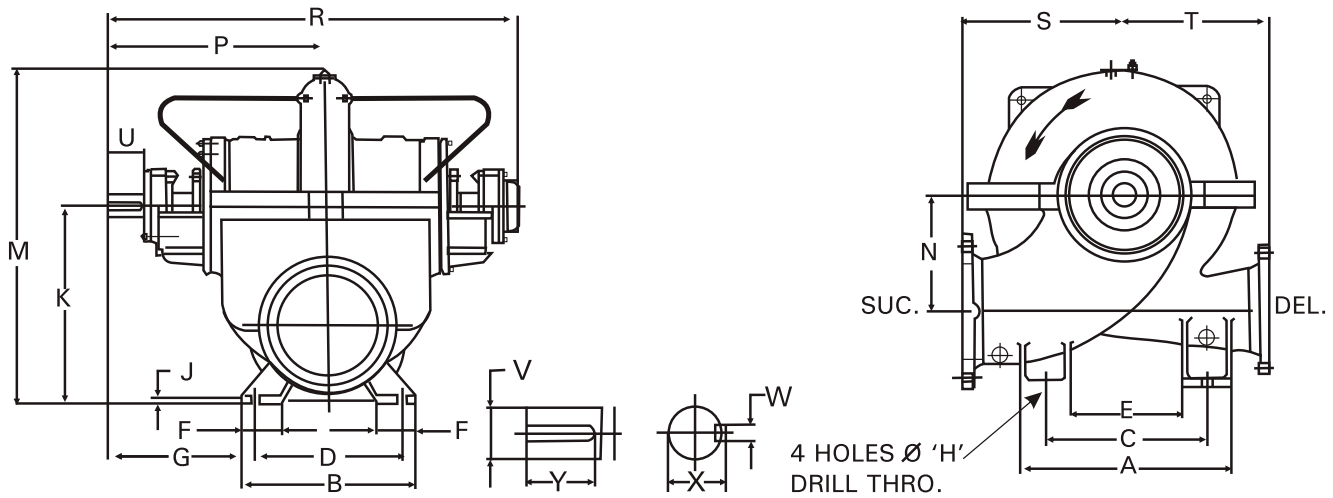

DIMENSIONS

Pump Model	Pump Mounting Dimensions																				WT			
	SUC	DEL	A	B	C	D	E	F	G	H	J	K	M	N	P	R	S	T	U	V	W	X	Y	kg
UP 250/57	300	250	650	520	500	440	350	120	418	27	25	600	1025	360	638	1218	500	450	100	68	20	72.5	72	1040
UP 300/46	350	300	710	500	560	400	410	150	438	27	25	630	1065	350	638	1218	575	475	100	68	20	72.5	72	1035
UP 300/57	350	300	890	560	750	500	590	120	460	27	35	650	1120	365	710	1300	650	550	135	80	22	85	131	1152
UP 350/54	400	350	850	600	700	500	450	130	428	27	25	740	1230	420	678	1298	725	500	100	68	20	72.5	72	1404
UP 350/66	400	350	950	600	750	500	550	120	525	27	25	760	1300	455	775	1415	725	575	150	80	22	85	146	1568
UP 400/46	400	400	850	600	700	500	450	110	445	27	25	720	1260	420	695	1326	700	550	90	55	16	59	78	990

* For clockwise Direction of Rotation.

GENERAL DIMENSIONS / MOUNTING DETAILS

UP (Metric) Pump

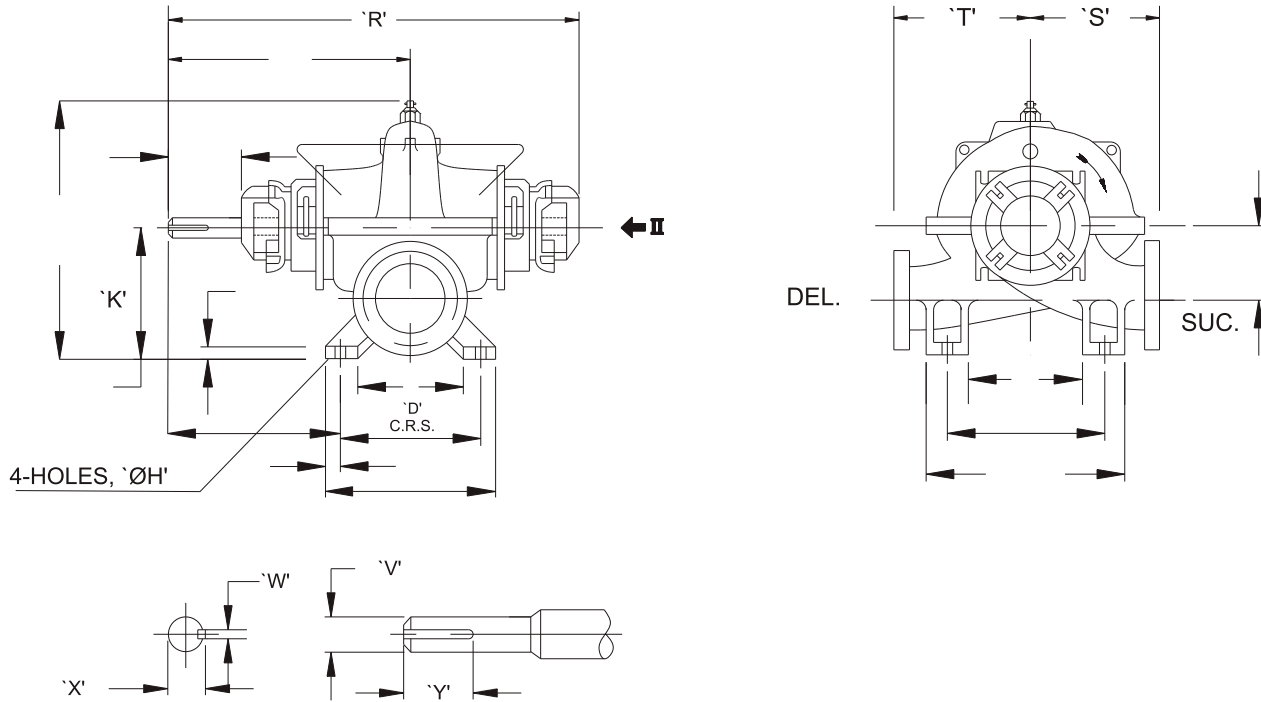

- NOTES :-
- 1) STANDARD DIRECTION OF ROTATION : COUNTER CLOCKWISE FROM DRIVING END
 - 2) NO CHANGE IN DIMENSIONS FOR CLOCKWISE DIRECTION OF ROTATION
 - 3) NO CHNAGE IN DIMENSIONS FOR MECH.SEAL ARRGT.EXCEPT UP250/33 PUMP.
 - 4) FLANGES DRILLED TO BS 4504 PN 16 (FF)
 - 5) ALL DIMENSIONS ARE IN mm

Pump Model	Pump Mounting Dimensions																				WT kg			
	SUC	DEL	A	B	C	D	E	F	G	H	J	K	M	N	P	R	S	T	U	V		W	X	Y
UP 200/56	250	200	710	500	560	400	410	150	392	27	30	600	1070	372	592	1077	550	450	110	55	16	59	85	740
UP 250/33	300	250	540	400	410	320	300	100	352	23	25	510	865	275	512	936	450	340	90	42	12	45	87	445
UP 250/46	300	250	650	520	500	440	350	120	392	27	25	575	965	320	612	1117	525	425	109	55	16	59	85	700
UP 300/34	350	300	710	500	560	400	410	150	383	27	25	600	1000	320	593	1102	550	450	85	42	12	45	87	678
UP 300/39	350	300	710	500	560	400	410	150	452	27	25	600	995	320	652	1197	525	450	109	55	16	59	85	755

GENERAL DIMENSIONS / MOUNTING DETAILS

UP(Metric) Pump

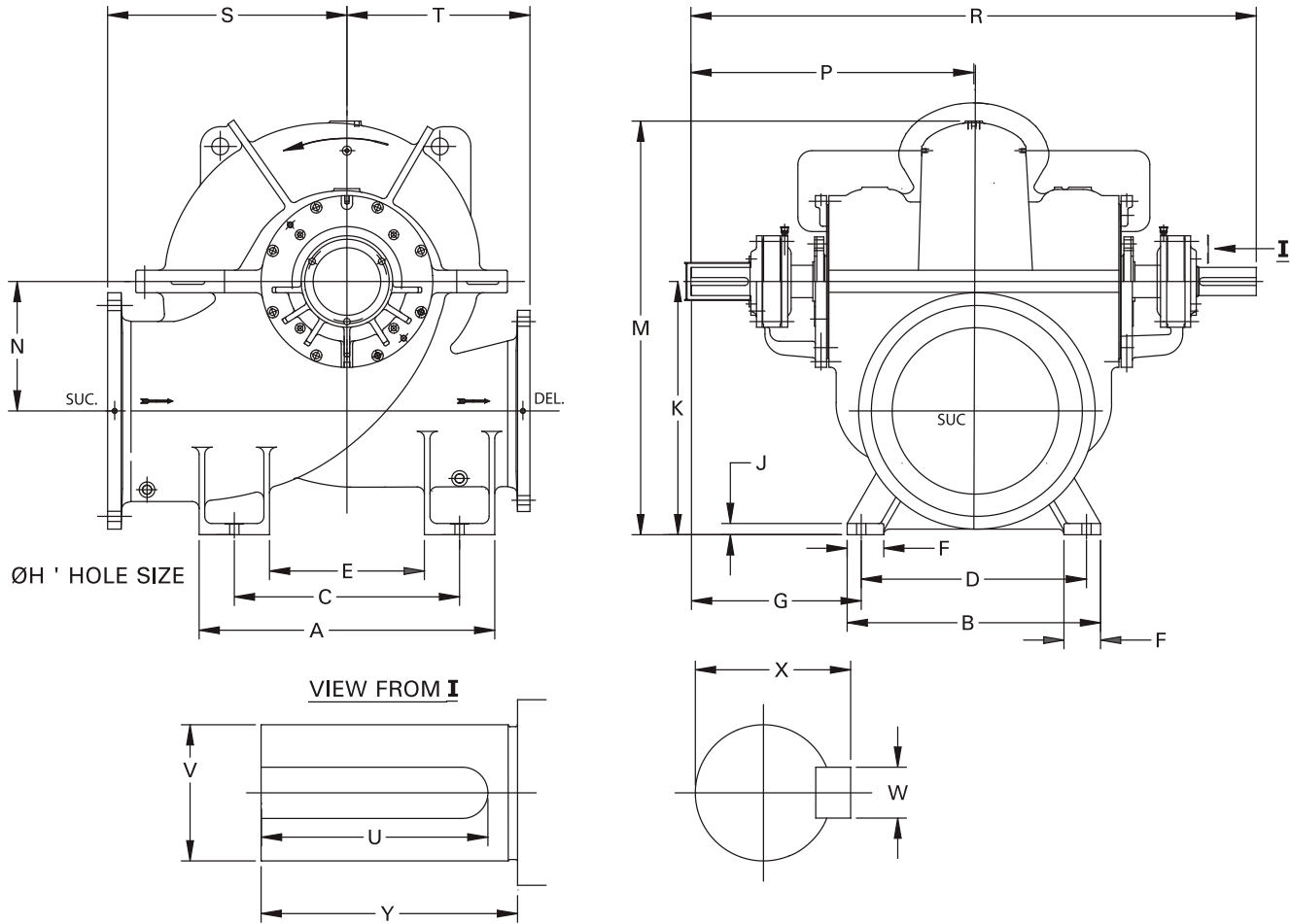

Pump Mounting Dimensions																							WT	
Pump Type	SUC	DEL	A	B	C	D	E	F	G	H	J	K	M	N	P	R	S	T	U	V (m6)	W	X	Y	kg
UP500/68	600	500	1050	900	800	800	550	130	605	33	40	900	1470	460	1005	2010	850	650	204	100 ^{+0.035} +0.013	28	106	210	2083
UP400/67	500	400	1020	720	820	600	620	130	593	27	35	900	1465	530	893	1786	850	650	162	95 ^{+0.013} +0.035	25	100	170	1773
UP400/48	450	400	1110	700	870	600	630	110	481	27	30	770	1280	440	781	1562	800	670	136	80 ^{+0.030} +0.011	22	85	140	1600
UP400/51	450	400	1110	700	870	600	630	110	481	27	30	770	1280	440	781	1562	800	670	136	80 ^{+0.030} +0.011	22	85	140	1650
UP500/51	600	500	1000	900	750	760	500	150	603	30	40	925	1505	495	983	1966	850	700	162	95 ^{+0.013} +0.035	25	100	170	2200

NOTES :

- 1) Standard direction of rotation : counter clockwise from driving end
- 2) No change in dimensions for clockwise direction of rotation
- 3) No change in dimensions for mech. seal arrangement
- 4) All dimensions are in mm
- 5) Flange drilled to BS 4504 PN 16 (FF)

GENERAL DIMENSIONS / MOUNTING DETAILS

UP/ UPL/ UPH Pump

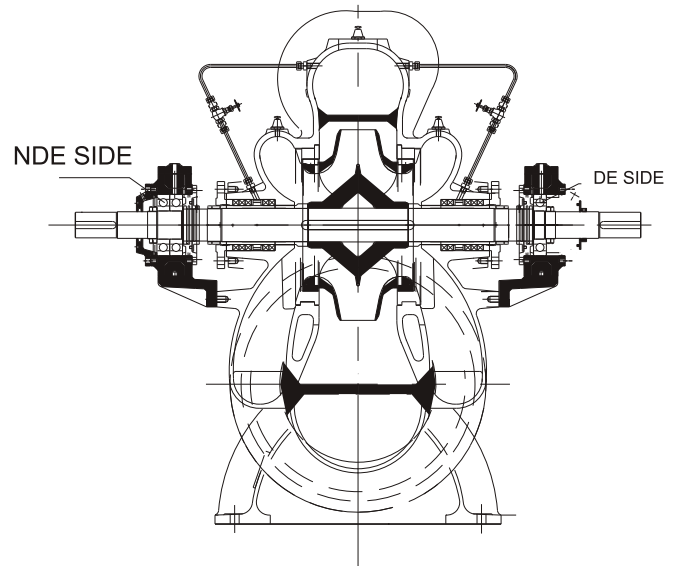
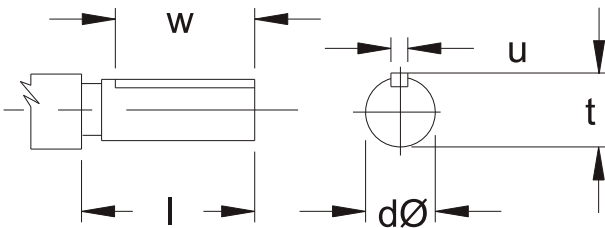
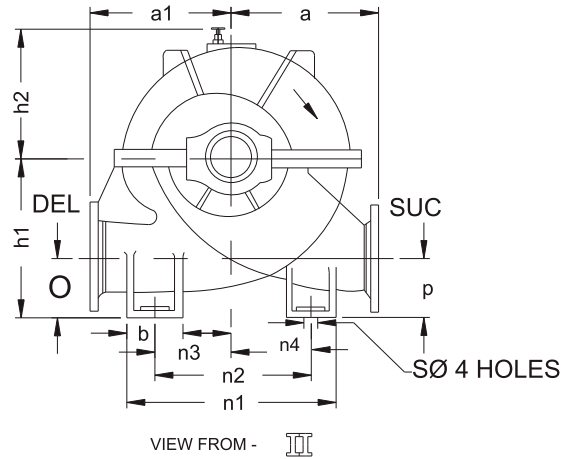
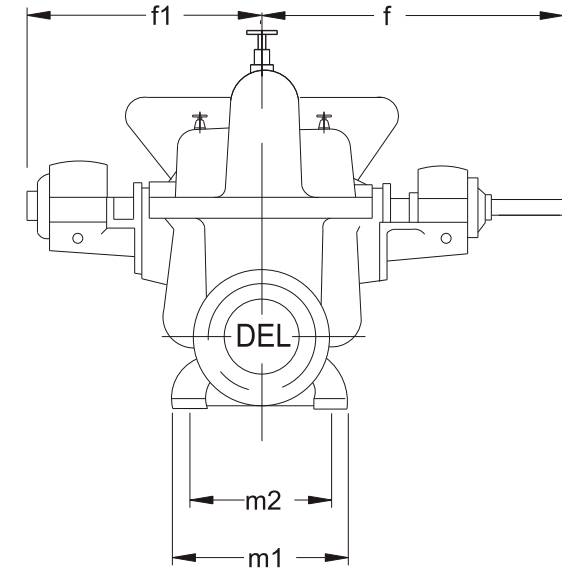

DIMENSIONS

Pump Type	SUC \varnothing	DEL \varnothing	Pump Mounting Dimensions																	Shaft End				WT KG	
			a	a1	f	f1	f2	h1	h2	O	P	b	m1	m2	n1	n2	n3	n4	sø	dø	l	t	u		w
UPH550/70(C)	650	550	1000	750	1165	960	715	1150	700	550	550	220	1000	900	1120	900	450	450	27	100	165	106	28	160	4500
24UPH3/M	760	610	1219	914	1105	871	623	1168	810	546	546	406	1118	965	1474	1270	635	635	33	100	165	106	28	160	5090
28UPL2	750	700	1235	890	1392	1310	792	1220	845	480	480	300	1400	1200	1710	1510	590	920	42	95	150	102	25	130	7015
30UPH1	750	750	1100	850	1165	980	683	1100	795	512	512	350	1115	965	1350	1150	575	575	33	100	165	108	28	145	4920
36UPH2	900	900	1550	1050	1710	1450	1110	1500	975	610	610	350	1400	1200	2000	1650	575	1075	39	175	250	185	45	240	12675
44UPH1A	1200	1100	1750	1350	1825	1600	825	1800	1230	800	800	400	2200	2000	2400	2000	850	1150	50	125	220	132	32	216	18618
20UPH3M2DV	600	600	1275	1050	1400	1175	950	1200	800	540	540	300	1005	900	1725	1425	825	600	41	115	185	122.4	32	180	4500
36UPH2M1	900	800	1426	960	1600	1350	1000	1429	874	610	610	350	1400	1200	1870	1520	530	990	39	125	220	132	32	216	9000
UPH1050/110	1050	1050	1675	1135	1925	1745	1275	1650	1050	710	710	380	1500	1300	2160	1780	620	1160	42	175	220	185.4	45	188	14000
UPH1200/160	1400	1200	2200	1684	2105	1800	1150	2200	1248	1100	1100	400	2200	2000	2400	2000	750	1050	42	160	275	168	40	240	18000

All dimensions are in mm

MATERIALS

MATERIAL OF CONSTRUCTION

Casing Half Upper / Lower	Cast Iron / Cast Steel / Stainless Steel / Duplex Steel
Impeller	Cast Iron / Bronze / Phosphor Bronze / Cast Steel / Stainless Steel / Chrome Steel / Duplex Steel
Wear Ring	Cast Iron / Bronze / Steel
Shaft	Carbon Steel / Stainless Steel / Duplex Steel
Shaft Sleeve	Stainless Steel / Bronze

MATERIAL STANDARDS - GENERAL INFORMATION

Material Type	Indian Standard (IS)	American standard (ASTM)	DIN
Cast Iron			
Cast Iron	IS 210 Gr. FG 260	ASTM A48 Class 40	(0.6025)DIN 1691 GG25
Spheroidal Graphite Cast Iron			
SG Iron (Ductile Iron)	IS 1865 Gr 400/15	A536, 60-40-18	(0.7040)DIN1693 GGG40
SG Iron (Ductile Iron)	IS 1865 Gr 500/7	A536, 65-45-12	(0.7050)DIN1693 GGG50
Carbon steel			
Carbon steel (Wrought)	IS 1570 (part II)Gr. 40C8	ASTM A107 Gr. 1040	(1.1186)C40E/CK40
Carbon steel (Wrought)	IS 1570 (part II) Gr. 20C8	ASTM A107 Gr. 1020	(1.0402)C22
MS Steel	MS IS 2062 - Fe 410 W A	ASTM-A283 GR.D	DIN 1700 GR ST4-2 FABRICATED STEEL44
Cast Steel Grades			
Cast steel		ASTMA 216 Gr. WCB	1.0619(GS-C25)
Cast Stainless Steel			
Stainless Steel CF8M	IS 3444 Gr. 4	ASTMA 351 Gr. CF8M	1.4408(GX5CrNiMo19-11-2)
Stainless Steel CF8M	IS 3444 Gr. 4	ASTMA 743 Gr. CF8M	1.4408(GX5CrNiMo19-11-2)
Stainless Steel CF3M	IS 3444 Gr. 16	ASTMA 351 Gr. CF3M	1.4409(GX2CrNiMo19-11-2)
Stainless Steel CF3M	IS 3444 Gr. 16	ASTMA 743 Gr. CF3M	1.4409(GX2CrNiMo19-11-2)
Stainless Steel CF8	IS 3444 Gr. 1	ASTMA 351 Gr. CF8	1.4301(X5CrNi18-10)
Stainless Steel CF3	IS 3444 Gr. 15	ASTMA 351 Gr. CF3	1.4306(X2CrNi19 11)
Cast Chromium StainlessSteel			
Stainless Steel CA15	IS 3444 Gr. 10	ASTMA 217 Gr. CA15	1.4106&1.448(DIN17445 GX12Cr14)
Stainless Steel CA15	IS 3444 Gr. 10	ASTMA 743 Gr. CA15	1.4106&1.448(DIN17445 GX12Cr14)
Stainless Steel CA6NM	IS 3444 Gr. 24	ASTMA 487 Gr. CA6NM	1.4313&1.4317(GX5CrNiMo13-4)
Stainless Steel CA6NM	IS 3444 Gr. 24	ASTMA 743 Gr. CA6NM	1.4313&1.4317(GX5CrNiMo13-4)
Chromium StainlessSteel Round Bar Material			
Stainless steel 410	IS 1570 (part V) Gr. X12Cr12	ASTMA 276 type 410	1.4006(X10Cr13)
Stainless steel 420	IS 1570 (part V) Gr. X20Cr13	ASTMA 276 type 420	1.4021(X20Cr13)
Stainless steel 431	IS 1570 (part V) Gr. X15Cr16Ni2	ASTMA 276 type 431	1.4057(X20CrNi17)
Stainless steel 316	IS 1570 (part V) Gr. X04Cr17Ni12Mo2	ASTMA 276 type 316	1.4401(X5CrNiMo17122)
Stainless steel 316L	IS 1570 (part V) Gr. X02Cr17Ni12Mo2	ASTMA 276 type316L	1.4404(X2CrNiMo1810)
Cast Duplex Steel			
Duplex Steel 1A		ASTMA 890 Gr. CD4MCu	25Cr-5Ni-Mo-Cu
Duplex Steel 2A		ASTMA 890 Gr. CE8MN	24Cr-10Ni-Mo-N
Duplex Steel 3A		ASTMA 890 Gr. CD6MN	25Cr-5Ni-Mo-N
Super Duplex steel 4A		ASTMA 890 Gr. CD3MN	25Cr-7Ni-Mo-N
Super Duplex steel 5A		ASTMA 890 Gr. CE3MN	24Cr-10Ni-Mo-N
Non Ferious Materials			
Bronze	IS 318 Gr. LTB2 (CuSn5Zn5Pb5C)	ASTMB 584 - C90500	DIN 1705 Rg 5
Phosphor Bronze	IS 28 Gr. 1 (CuSn11PC)		
Zinc Free Bornze	IS 28 Gr. 1 (CuSn10C)		

FAMILY CURVES

UP Pumps at 50 Hz

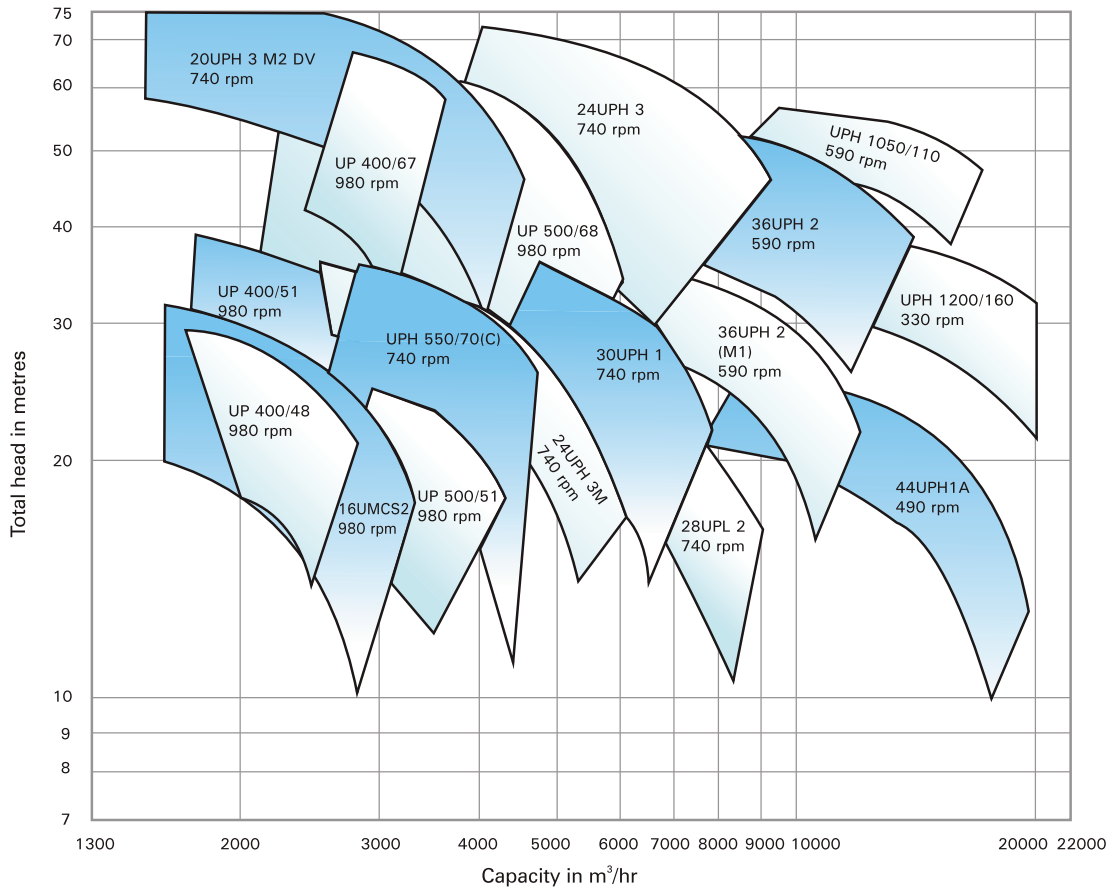

UP (Metric) Pumps at 1450 rpm - 50 Hz

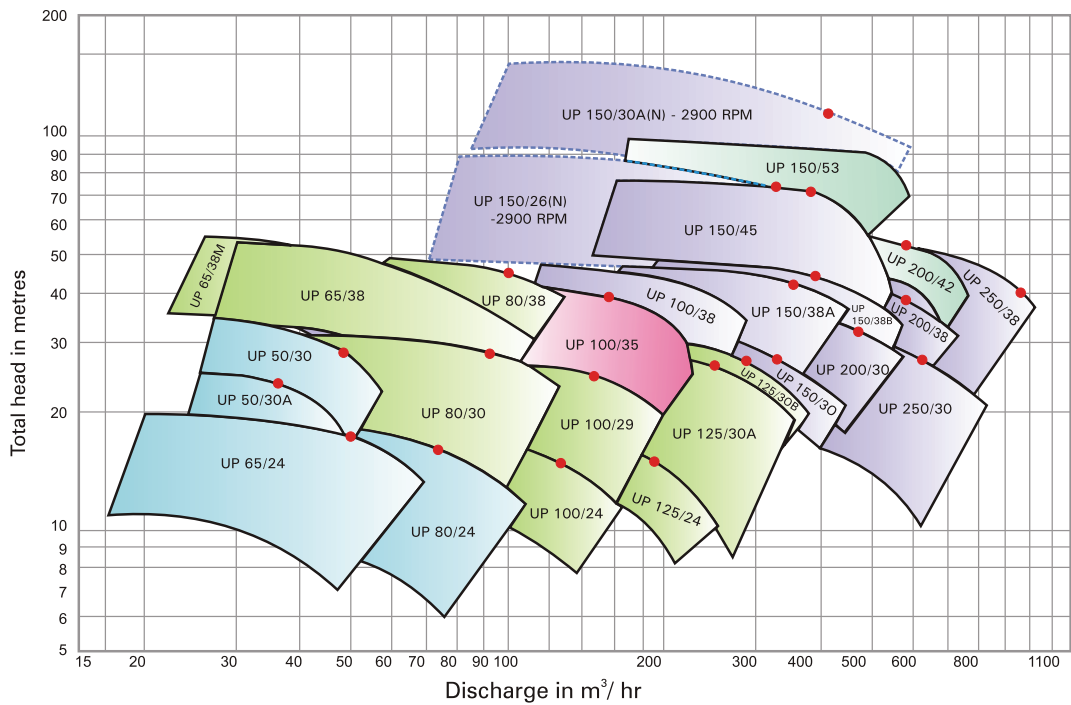

■ Module No. O
 ■ Module No. I
 ■ Module No. IE
 ■ Module No. II
 ■ Module No. III

FAMILY CURVES

UP/ UPL/ UPH Pumps at - 50Hz

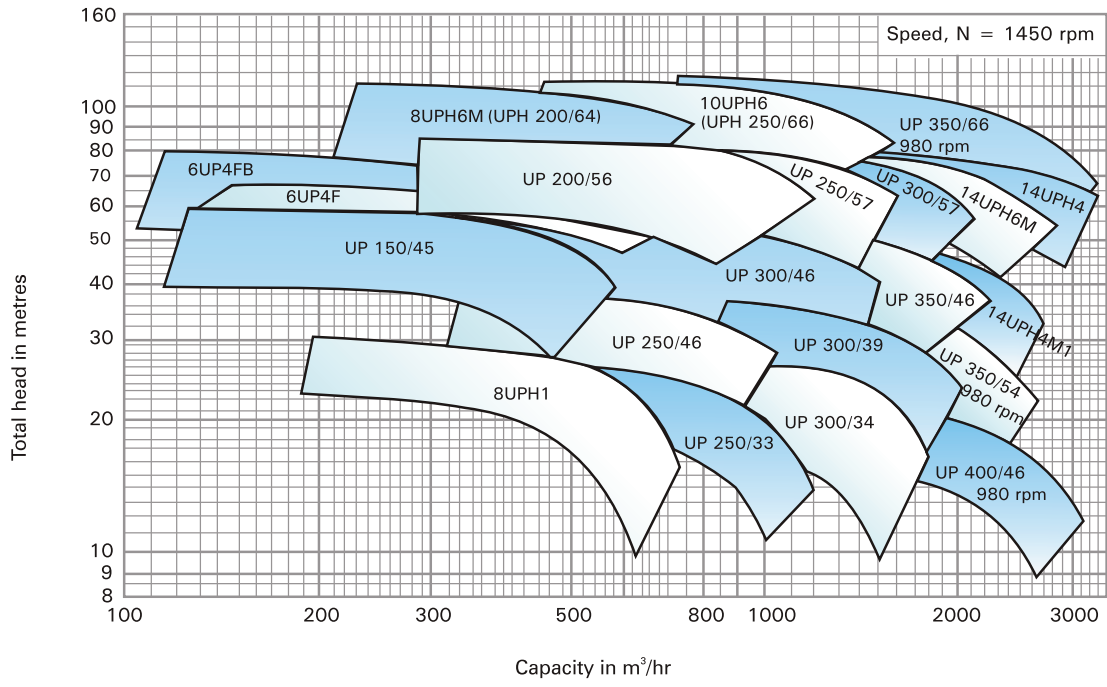

OUR GLOBAL PRESENCE



As we are constantly endeavouring to improve the performance of our products/ equipment, we reserve the right to make alterations from time to time and as such our products/ equipment may differ from that detailed in this publication. For latest information you may get in touch with our Regional Sales Offices.



Enriching Lives

KIRLOSKAR BROTHERS LIMITED

CORPORATE OFFICE :

"YAMUNA", Survey No. 98 (3/7), Baner,
Pune - 411045, INDIA
Tel.: +91 20 27214444 Fax: +91 20 27211117
email: kblin@kbl.co.in website: www.kbl.co.in

WORKS :

Kirloskarvadi 416308 Dist. Sangli
Maharashtra, INDIA
Tel.: +91 2346 222301 to 222305
Fax: +91 2346 222311



KIRLOSKAR BROTHERS LIMITED